

- NOTES:
- MATERIAL:
 - HOUSING: THERMOPLASTIC, HIGH TEMP., UL94V-0; COLOR:BLACK.
 - CONTACT: PHOSPHOR BRONZE
 - LATCH: SUS
 - FINISH:
 - CONTACT:SEE ORDER INFORMATION.
 - UNDERPLATING: 50~100u" NICKEL OVERALL.
 - REFLOW SOLDER CAPABLE TO 260°C PER ACES SPEC.
 - LOGO/MARK HEIGHT 0.01mm ABOVE SURFACE
 - SPEC. PLS. REFER TO PS-52747-xxxxx-xxx
 - PACKAGE PLS. REFER TO 52747-xxxCR-U
 - PART NUMBER
52747-xxx X X -001

CKTS _____ CONTACT PLATED
 262. 262PIN 2.GOLD FLASH ON CONTACT
 PACKAGE _____ G.GOLD 10u" ON CONTACT
 O.TAPE & REEL 1.GOLD 1u" ON CONTACT

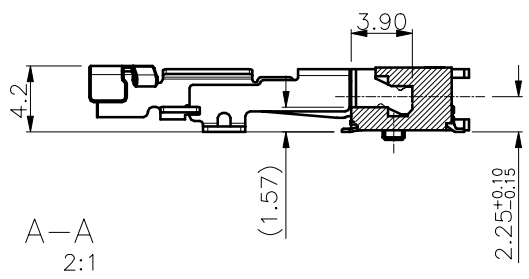

QUALITY SYMBOLS MAJOR CRITICAL GENERAL TOLERANCES (UNLESS SPECIFIED) X. ±0.5 .X ±0.25 .XX ±0.15 .XXX ±0.1 ANGLES ±2°	DRAWN BY CHEN CHUN YUAN 23'/08/30	DATE 23'/08/30		
	CHECKED BY TSOI CHIAO 23'/08/30	DATE 23'/08/30		
	APPROVED BY HUANG KUO HUA 23'/08/30	DATE 23'/08/30		
	TITLE DDR 5 CONN. 262 Pin H 4.0 RVS Type			
UNITS mm		SIZE A4	RFQ NO. N/A	DWG NO. 52747-xxxxx-xxx
SCALE 1:1	SHEET NO. 1 OF 2	REV D		

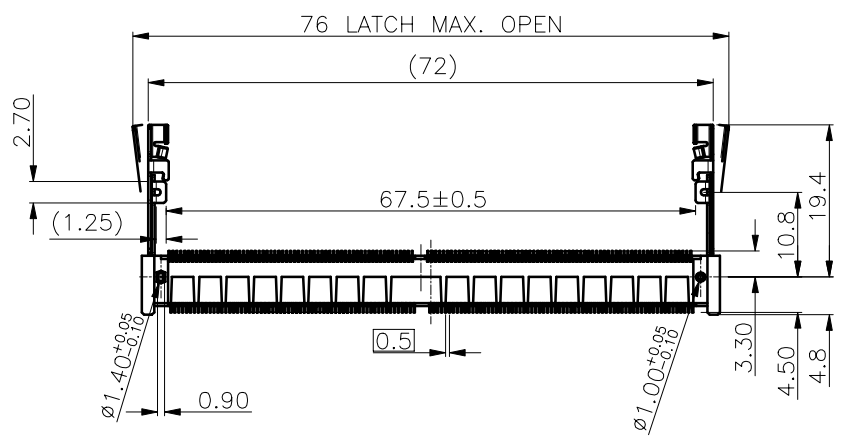
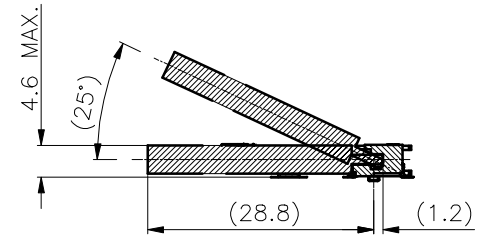
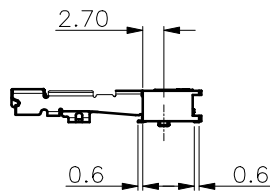
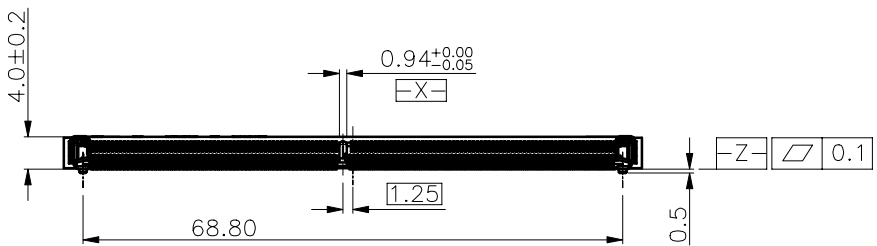
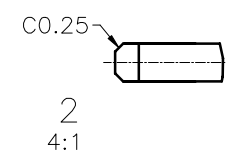
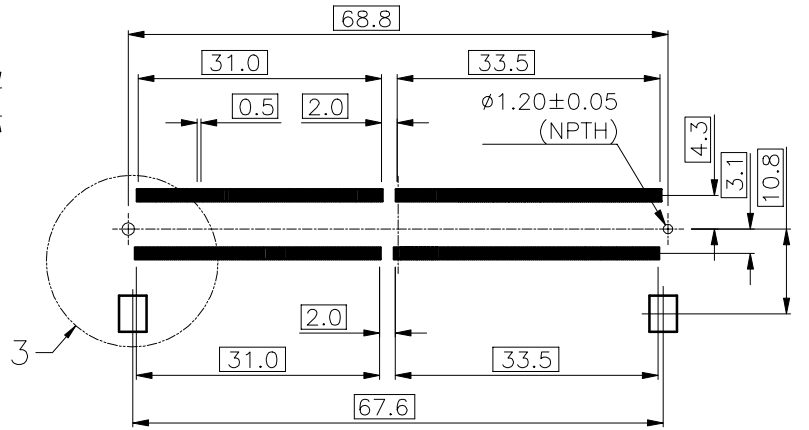
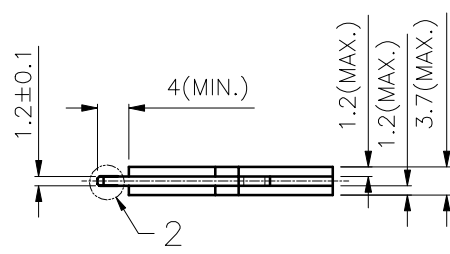
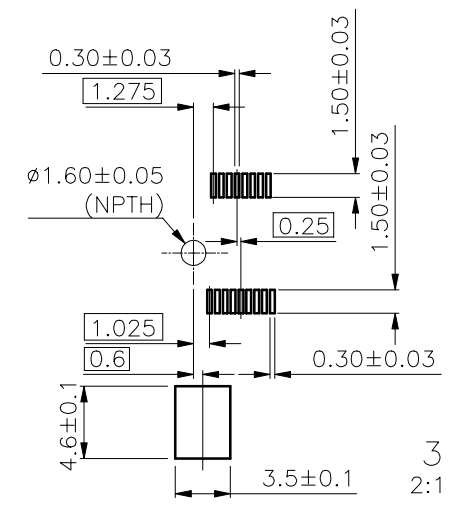
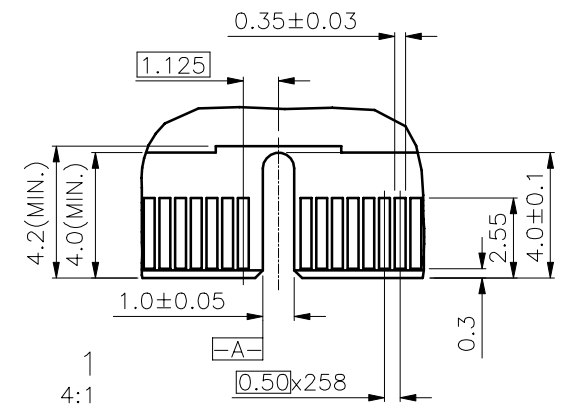
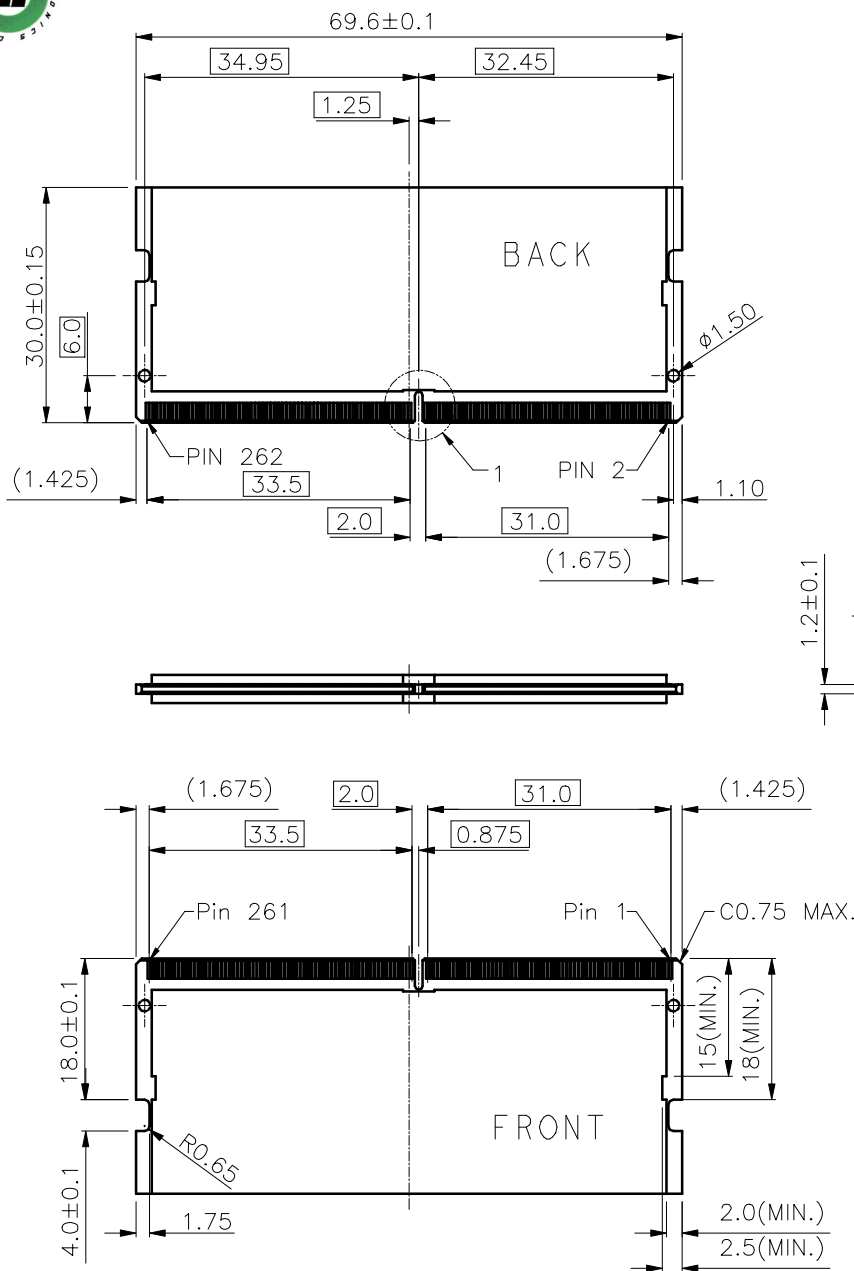

RECOMMEND PCB LAYOUT(STANDARD)
THE TOLERANCE UNLESS SPECIFIED IS ±0.05MM

QUALITY SYMBOLS MAJOR Ⓢ CRITICAL Ⓢ GENERAL TOLERANCES (UNLESS SPECIFIED) X. ±0.5 .X ±0.25 .XX ±0.15 .XXX ±0.1 ANGLES ±2°	DRAWN BY CHEN CHUN YUAN 23'/08/30	DATE 23'/08/30	
	CHECKED BY TSOI CHIAO 23'/08/30	DATE 23'/08/30	
	APPROVED BY HUANG KUO HUA 23'/08/30	DATE 23'/08/30	Rfq NO. N/A
	UNITS mm		SIZE A4
	SCALE 1:1	SHEET NO. 2 OF 2	REV D
			DWG NO. 52747-xxxxx-xxx